

# C503C-RCN-CYBYCAA2 Datasheet



DiGi Electronics Part Number	C503C-RCN-CYBYCAA2-DG
Manufacturer	<a href="#">CreeLED, Inc.</a>
Manufacturer Product Number	C503C-RCN-CYBYCAA2
Description	LED RED CLEAR 5MM ROUND T/H
Detailed Description	Red 624nm LED Indication - Discrete 2.1V Radial

<https://www.DiGi-Electronics.com>

This model C503C-RCN-CYBYCAA2 is available at DiGi Electronics.

DiGi Electronics offers a global database of semiconductor and electronic component datasheets.

We welcome your inquiries regarding pricing, lead time, or other product-related questions.

 [Request a Quote](#)

 [Datasheet Search](#)



Tel: +00 852-30501935

RFQ Email: [Info@DiGi-Electronics.com](mailto:Info@DiGi-Electronics.com)

DiGi is a global authorized distributor of electronic components.

## Purchase and inquiry

Manufacturer Product Number:

C503C-RCN-CYBYCAA2

Series:

-

Color:

Red

Lens Color:

Colorless

Millicandela Rating:

7350mcd

Lens Size:

5.00mm Dia

Current - Test:

20mA

Mounting Type:

Through Hole

Wavelength - Peak:

-

Package / Case:

Radial

Size / Dimension:

-

Base Product Number:

C503C

Manufacturer:

CreeLED, Inc.

Product Status:

Active

Configuration:

Standard

Lens Transparency:

Clear

Lens Style:

Round with Domed Top

Voltage - Forward (Vf) (Typ):

2.1V

Viewing Angle:

30°

Wavelength - Dominant:

624nm

Features:

-

Supplier Device Package:

5mm Round

Height (Max):

8.60mm

## Environmental & Export classification

RoHS Status:

RoHS Compliant

REACH Status:

REACH Unaffected

HTSUS:

8541.41.0000

Moisture Sensitivity Level (MSL):

1 (Unlimited)

ECCN:

EAR99

## C503C-Rxx, C503C-Axx: 5-mm Round Red & Amber LEDs

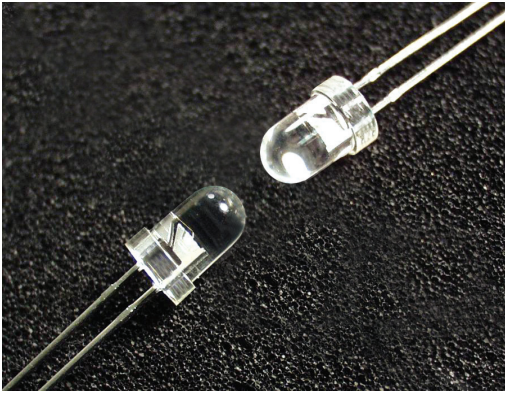

### PRODUCT DESCRIPTION

Round LEDs offer superior light output for excellent readability in sunlight and dependable performance. They provide extremely stable light output over long periods of time.

These lamps are made with an advanced optical-grade epoxy offering superior high-temperature and high-moisture-resistance performance in outdoor signal and sign applications.

### FEATURES

- Size (mm): 5
- Color and Typical Dominant Wavelength:  
Red (624nm)  
Amber (591nm)
- Luminous Intensity (mcd)  
C503C-RCS/RCN:(5860 - 10100)  
C503C-ACS/ACN:(5860 - 10100)
- Viewing angles:  
30°: C503C-RCS/RCN/ACS/ACN
- Lead - Free
- RoHS Compliant

### APPLICATIONS

- Electronic Signs & Signals (ESS)
- Motorway Signs
- Variable Message Sign (VMS)
- Advertising Signs
- Petrol Signs
- Amusement

## ABSOLUTE MAXIMUM RATINGS ( $T_A = 25^\circ\text{C}$ )

Items	Symbol	Absolute Maximum Rating	Unit
		Red/Amber	
Forward Current	$I_F$	50 <sup>Note1</sup>	mA
Peak Forward Current <sup>Note2</sup>	$I_{FP}$	200	mA
Reverse Voltage	$V_R$	5	V
Power Dissipation	$P_D$	130	mW
Operation Temperature	$T_{opr}$	-40 ~ +100	$^\circ\text{C}$
Storage Temperature	$T_{stg}$	-40 ~ +100	$^\circ\text{C}$
Lead Soldering Temperature	$T_{sol}$	Max. 260 $^\circ\text{C}$ for 3 sec. max. (3 mm from the base of the epoxy bulb)	
Electrostatic Discharge Classification (MIL-STD-883E)	ESD	Class 2	

### Note:

- For long term performance the drive currents between 10mA and 30mA are recommended. Please contact Cree LED sales representative for more information on recommended drive conditions.
- Pulse width  $\leq 0.1$  msec, duty  $\leq 1/10$ .

## TYPICAL ELECTRICAL & OPTICAL CHARACTERISTICS ( $T_A = 25^\circ\text{C}$ )

Characteristics	Color	Symbol	Condition	Unit	Minimum	Typical	Maximum
Forward Voltage	Red/Amber	$V_F$	$I_F = 20$ mA	V		2.1	2.6
Reverse Current	Red/Amber	$I_R$	$V_R = 5$ V	$\mu\text{A}$			100
Dominant Wavelength	Red	$\lambda_D$	$I_F = 20$ mA	nm	618	624	630
	Amber	$\lambda_D$	$I_F = 20$ mA	nm	584	591	596
Luminous Intensity	Red	C503C-RCS/RCN	$I_V$	$I_F = 20$ mA	mcd	5860	7400
	Amber	C503C-ACS/ACN	$I_V$	$I_F = 20$ mA	mcd	5860	7600
50% Power Angle	C503C-RCS/RCN/ACS/ACN		$2\theta_{1/2}$	$I_F = 20$ mA	deg	30	

\* Continuous reverse voltage can cause LED damage.

## INTENSITY BIN LIMIT

### Red

30°(20 mA) - C503C-RCS/RCN								
Bin Code	Min.(mcd)	Max.(mcd)	Bin Code	Min.(mcd)	Max.(mcd)	Bin Code	Min.(mcd)	Max.(mcd)
Y0	5860	8200	Ya	5860	7030	YA	5860	6500
			Yb	7030	8200	YB	6500	7200
						YC	7200	8200
Z0	8200	12000	Za	8200	10100			

### Amber

30°(20 mA) - C503C-ACS/ACN								
Bin Code	Min.(mcd)	Max.(mcd)	Bin Code	Min.(mcd)	Max.(mcd)	Bin Code	Min.(mcd)	Max.(mcd)
Y0	5860	8200	Ya	5860	7030	YA	5860	6500
			Yb	7030	8200	YB	6500	7200
						YC	7200	8200
Z0	8200	12000	Za	8200	10100			

\* Tolerance of measurement of luminous intensity is  $\pm 15\%$

## COLOR BIN LIMIT

Red (20 mA) - C503C-Rxx			Amber (20 mA) - C503C-Axx		
Bin Code	Min.(nm)	Max.(nm)	Bin Code	Min.(nm)	Max.(nm)
RA	618	630	A2	584	587
			A3	587	590
			A4	590	593
			A5	593	596

\* Tolerance of measurement of dominant wavelength is  $\pm 1$  nm.

## ORDER CODE TABLE

Color	Viewing Angle	Order Code	Luminous Intensity (mcd)		Dominant Wavelength				Package	Standoff
			Min.	Max.	Color Bin	Min.(nm)	Color Bin	Max.(nm)		
Red	30°	C503C-RCS-CYAZaAA1	5860	10100	RA	618	RA	630	Bulk	Yes
		C503C-RCS-CYBYCAA1	6500	8200	RA	618	RA	630	Bulk	Yes
		C503C-RCS-CYCZaAA1	7200	10100	RA	618	RA	630	Bulk	Yes
		C503C-RCS-CYAZaAA2	5860	10100	RA	618	RA	630	Ammo	Yes
		C503C-RCS-CYBYCAA2	6500	8200	RA	618	RA	630	Ammo	Yes
		C503C-RCS-CYCZaAA2	7200	10100	RA	618	RA	630	Ammo	Yes
		C503C-RCN-CYAZaAA1	5860	10100	RA	618	RA	630	Bulk	No
		C503C-RCN-CYBYCAA1	6500	8200	RA	618	RA	630	Bulk	No
		C503C-RCN-CYCZaAA1	7200	10100	RA	618	RA	630	Bulk	No
		C503C-RCN-CYAZaAA2	5860	10100	RA	618	RA	630	Ammo	No
		C503C-RCN-CYBYCAA2	6500	8200	RA	618	RA	630	Ammo	No
		C503C-RCN-CYCZaAA2	7200	10100	RA	618	RA	630	Ammo	No

## Notes:

- The above kit numbers represent order codes that include multiple intensity-bin and color-bin codes. Only one intensity-bin code and one color-bin code will be shipped on each bulk. Single intensity-bin code and single color-bin codes will not be orderable.
- Please refer to the [HB LED Lamp Reliability Test Standards](#) document for reliability test conditions.
- Please refer to the [HB LED Lamp Soldering & Handling](#) document for information about how to use this LED product safely.

## ORDER CODE TABLE

Color	Viewing Angle	Order Code	Luminous Intensity (mcd)		Dominant Wavelength				Package	Standoff
			Min.	Max.	Color Bin	Min.(nm)	Color Bin	Max.(nm)		
Amber	30°	C503C-ACS-CYAZa251	5860	10100	A2	584	A5	596	Bulk	Yes
		C503C-ACS-CYAZa341	5860	10100	A3	587	A4	593	Bulk	Yes
		C503C-ACS-CYCZa251	7200	10100	A2	584	A5	596	Bulk	Yes
		C503C-ACS-CYCZa341	7200	10100	A3	587	A4	593	Bulk	Yes
		C503C-ACS-CYAZa252	5860	10100	A2	584	A5	596	Ammo	Yes
		C503C-ACS-CYAZa342	5860	10100	A3	587	A4	593	Ammo	Yes
		C503C-ACS-CYCZa252	7200	10100	A2	584	A5	596	Ammo	Yes
		C503C-ACS-CYCZa342	7200	10100	A3	587	A4	593	Ammo	Yes
		C503C-ACN-CYAZa251	5860	10100	A2	584	A5	596	Bulk	No
		C503C-ACN-CYAZa341	5860	10100	A2	584	A4	593	Bulk	No
		C503C-ACN-CYCZa251	7200	10100	A3	587	A5	596	Bulk	No
		C503C-ACN-CYCZa341	7200	10100	A3	587	A4	593	Bulk	No
		C503C-ACN-CYAZa252	5860	10100	A2	584	A5	596	Ammo	No
		C503C-ACN-CYAZa342	5860	10100	A2	584	A4	593	Ammo	No
		C503C-ACN-CYCZa252	7200	10100	A3	587	A5	596	Ammo	No
		C503C-ACN-CYCZa342	7200	10100	A3	587	A4	593	Ammo	No

## Notes:

- The above kit numbers represent order codes that include multiple intensity-bin and color-bin codes. Only one intensity-bin code and one color-bin code will be shipped on each bulk. Single intensity-bin code and single color-bin codes will not be orderable.
- Please refer to the [HB LED Lamp Reliability Test Standards](#) document for reliability test conditions.
- Please refer to the [HB LED Lamp Soldering & Handling](#) document for information about how to use this LED product safely.

**GRAPHS**

The data below are collected from statistical figures that do not necessarily correspond to the actual parameters of each single LED. Hence, these data will be changed without further notice.

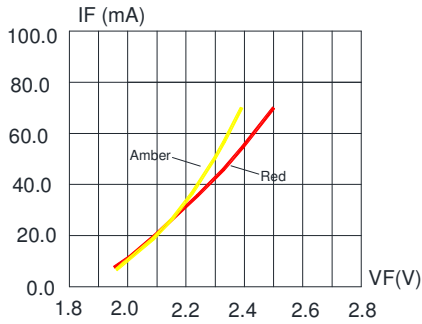

FIG.1 FORWARD CURRENT VS. FORWARD VOLTAGE.

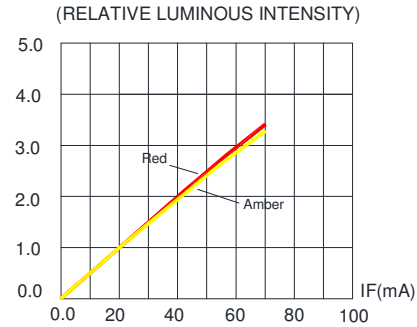

FIG.2 RELATIVE LUMINOUS INTENSITY VS. FORWARD CURRENT

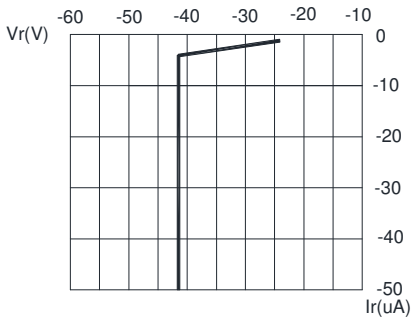

FIG.3 RED & AMBER REVERSE CURRENT VS. REVERSE VOLTAGE.

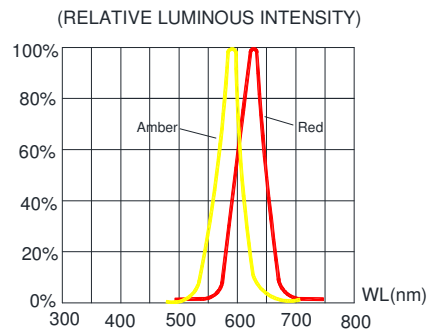

FIG.4 RELATIVE LUMINOUS INTENSITY VS. WAVELENGTH.

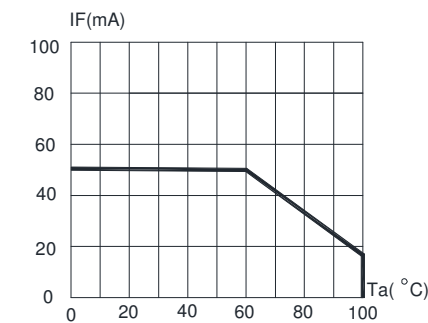

FIG.5 RED & AMBER MAXIMUM FORWARD DC CURRENT VS AMBIENT TEMPERATURE ( $T_{jmax}=110^{\circ}C$ )

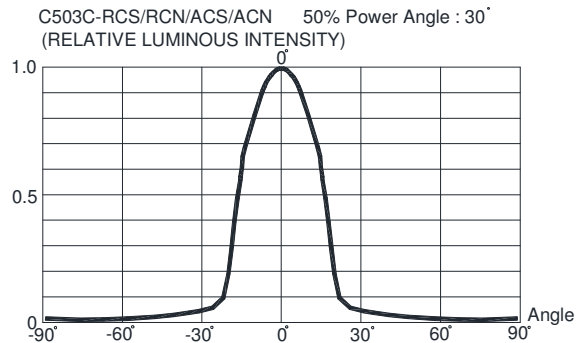

FIG.6 FAR FIELD PATTERN

## MECHANICAL DIMENSIONS

All dimensions are in mm. Tolerance is  $\pm 0.25$  mm unless otherwise noted.

An epoxy meniscus may extend about 1.5 mm down the leads.

Burr around bottom of epoxy may be 0.5 mm max.

**C503C-RCS:**

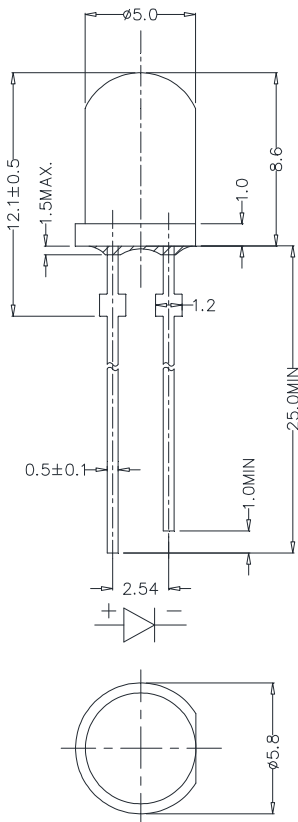

**C503C-ACS:**

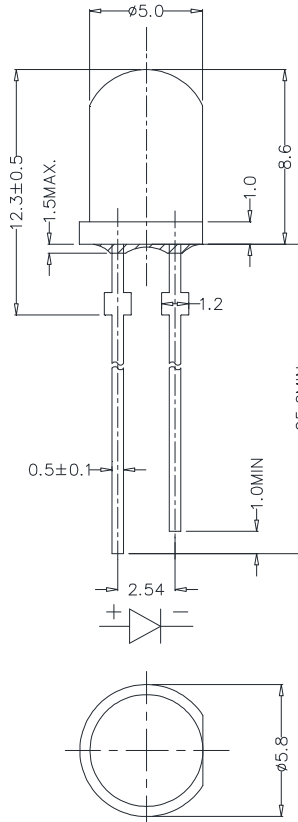

**C503C-RCN/ACN:**

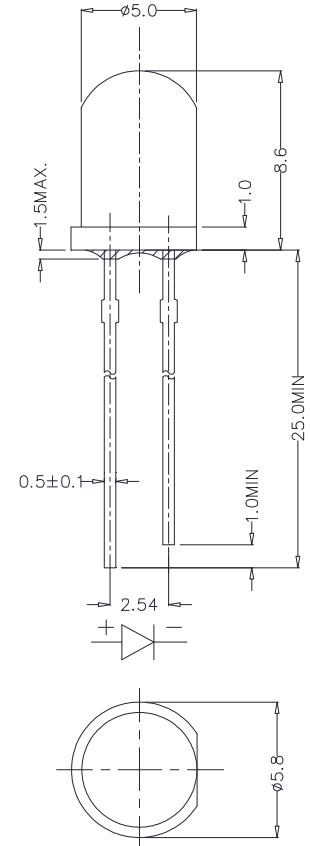

## NOTES

### RoHS Compliance

The levels of RoHS restricted materials in this product are below the maximum concentration values (also referred to as the threshold limits) permitted for such substances, or are used in an exempted application, in accordance with EU Directive 2011/65/EC (RoHS2), as implemented January 2, 2013. RoHS Declarations for this product can be obtained from your Cree LED representative or from the [Product Ecology](#) section of the Cree LED website.

### Vision Advisory

**WARNING:** Do not look at an exposed lamp in operation. Eye injury can result.

## KIT NUMBER SYSTEM

Cree LED lamps are tested and sorted into performance bins. A bin is specified by ranges of color, forward voltage, and brightness. Sorted LEDs are packaged for shipping in various convenient options.

Cree LEDs are sold by order codes in combinations of bins called kits. Order codes are configured in the following manner:

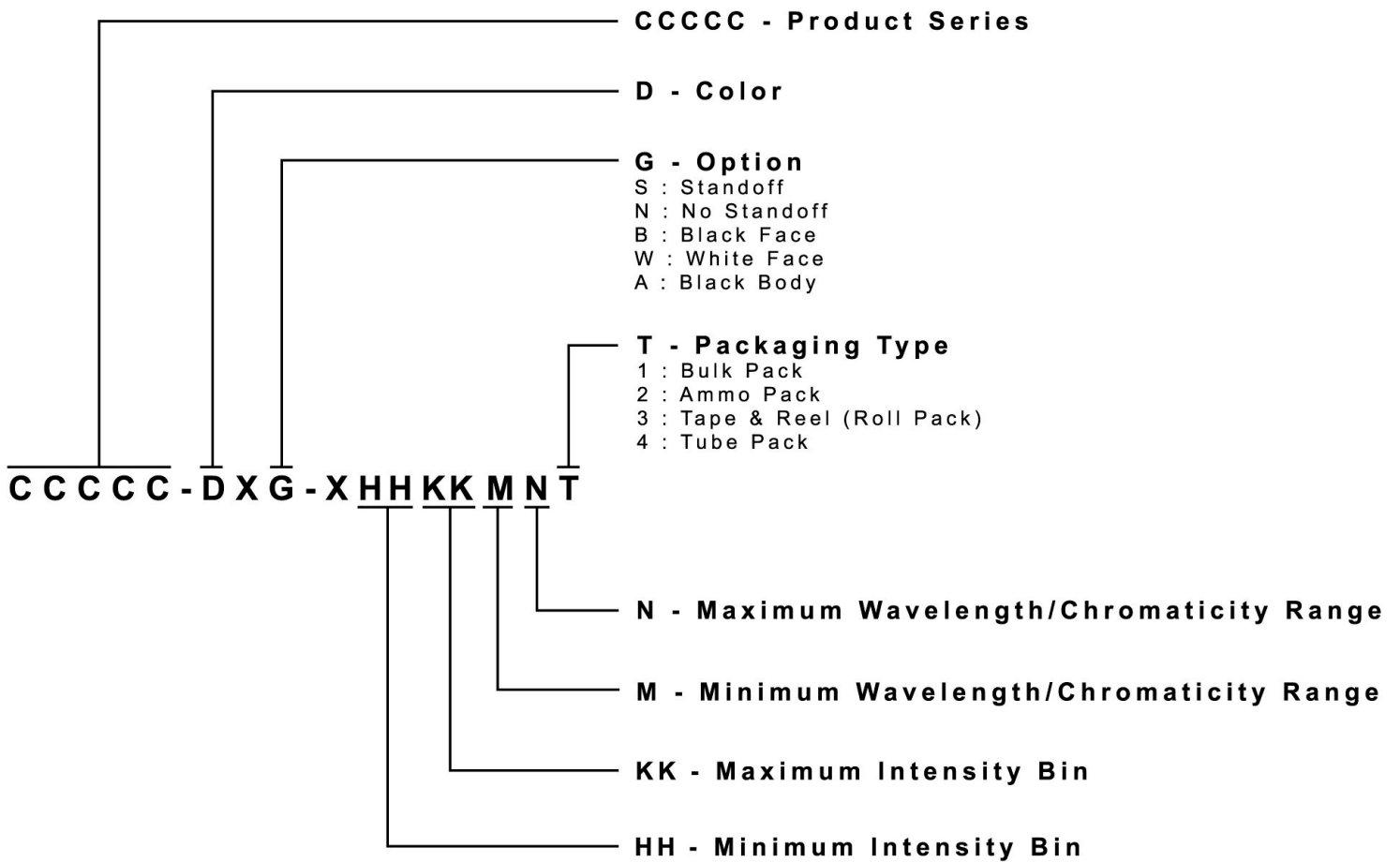

## SOLDERING GUIDELINES

The LED soldering specification is shown below (suitable for both leaded solder & lead-free solder):

Manual Soldering		Solder Dipping	
Soldering iron	35 W max	Preheat	110 °C max
Temperature	300 °C max	Preheat time	60 seconds max
		Solder-bath temperature	260 °C Max
Soldering time	3 seconds max	Dipping time	5 seconds max
Position	Not less than 3 mm from the base of the package.	Position	Not less than 3 mm from the base of the package.

- Manual soldering onto the PCB is not recommended because soldering time is uncontrollable.
- The recommended wave soldering is as below:

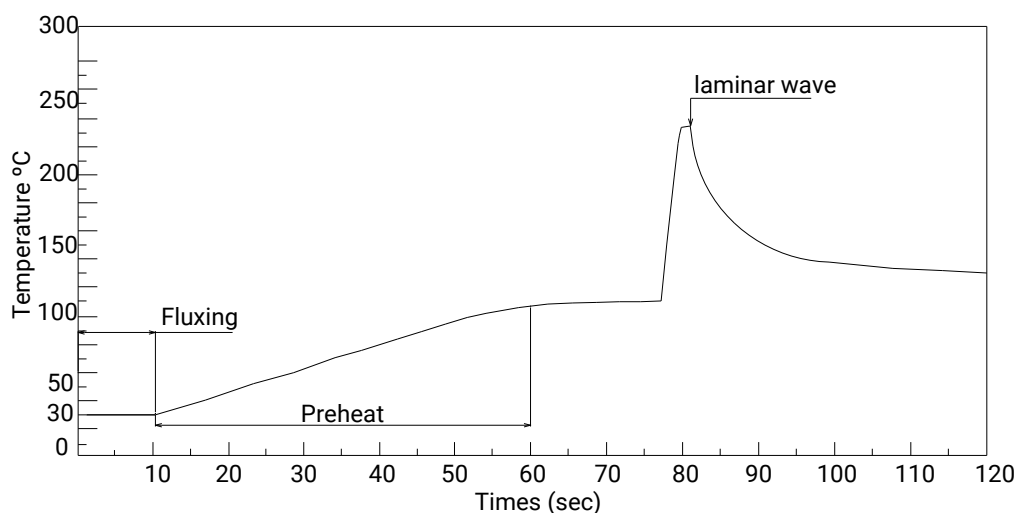

- Do not apply any stress to the LED package, particularly when heated.
- Only bottom preheat is suggested & should not preheat on top in order to reduce thermal stress experienced by the LEDs.
- The LEDs must not be re used once they have been extracted from PCB.
- After soldering the LEDs, the package should be protected from mechanical shock or vibration until the LEDs have reached 40 °C or below.
- Precautions must be taken as mechanical stress on the LEDs may be caused by PCB warpage or from the clinching and cutting of the LED leads.
- When it is necessary to clamp the LEDs during soldering, it is important to ensure no mechanical stress is exerted on the LEDs.
- Cut the LED lead at normal room temperature. Lead cutting at high temperature may cause failure of the LEDs.
- Please refer to the [HB LED Lamp Soldering & Handling](#) document for information about how to use this LED product safely.

## PACKAGING

- The LEDs are packed in cardboard boxes after packaging in normal or anti-electrostatic bags.
- Cardboard boxes will be used to protect the LEDs from mechanical shock during transportation.
- The boxes are not water resistant, and they must be kept away from water and moisture.
- Max 500 pcs per bulk and Max 2500 pcs per ammo.

### Bulk Pack Packaging Type:

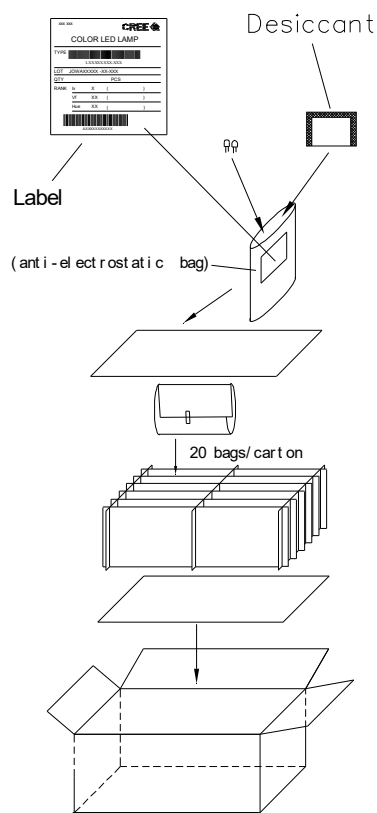

### Ammo Pack Packaging Type:

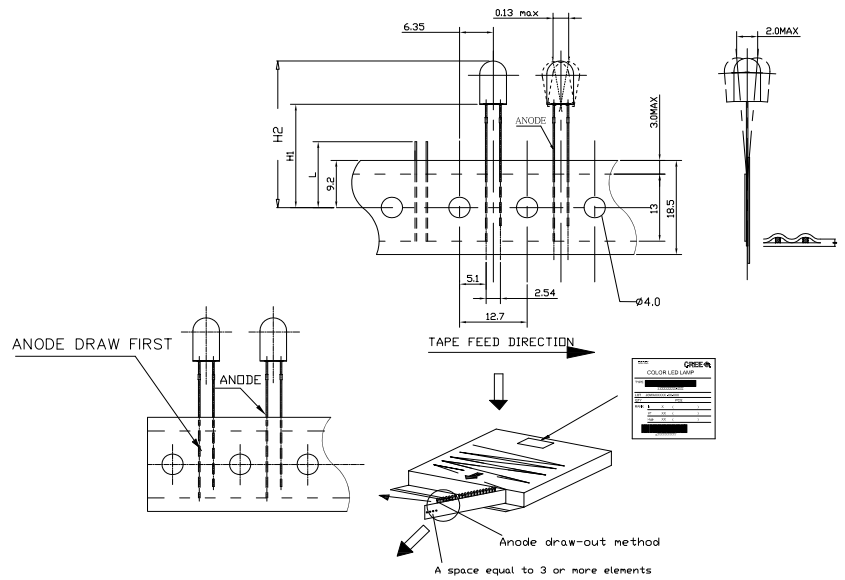

## OUR CERTIFICATE

DiGi provide top-quality products and perfect service for customer worldwide through standardization, technological innovation and continuous improvement. DiGi through third-party certification, we stricly control the quality of products and services. Welcome your RFQ to

Email: [Info@DiGi-Electronics.com](mailto:Info@DiGi-Electronics.com)



Tel: +00 852-30501935

RFQ Email: [Info@DiGi-Electronics.com](mailto:Info@DiGi-Electronics.com)

DiGi is a global authorized distributor of electronic components.