

# CS-SM-MSC Datasheet



<https://www.DiGi-Electronics.com>

DiGi Electronics Part Number	CS-SM-MSC-DG
Manufacturer	<a href="#">Crystek Corporation</a>
Manufacturer Product Number	CS-SM-MSC
Description	CONN SMA PLUG STR SOLDER
Detailed Description	SMA Connector Plug, Male Pin Free Hanging (In-Line) Solder

This model CS-SM-MSC is available at DiGi Electronics.

DiGi Electronics offers a global database of semiconductor and electronic component datasheets.

We welcome your inquiries regarding pricing, lead time, or other product-related questions.

 [Request a Quote](#)

 [Datasheet Search](#)



Tel: +00 852-30501935

RFQ Email: [Info@DiGi-Electronics.com](mailto:Info@DiGi-Electronics.com)

DiGi is a global authorized distributor of electronic components.

## Purchase and inquiry

Manufacturer Product Number:

CS-SM-MSC

Series:

-

Connector Style:

SMA

Contact Termination:

Solder

Impedance:

-

Mounting Feature:

-

Fastening Type:

Threaded

Features:

-

Ingress Protection:

-

Includes:

-

Body Finish:

-

Dielectric Material:

Polytetrafluoroethylene (PTFE)

Mating Cycles:

-

Base Product Number:

-

Manufacturer:

Crystek Corporation

Product Status:

Obsolete

Connector Type:

Plug, Male Pin

Shield Termination:

Clamp

Mounting Type:

Free Hanging (In-Line)

Cable Group:

Semflex HP190

Number of Ports:

1

Housing Color:

Silver

Center Contact Material:

Beryllium Copper

Body Material:

Stainless Steel

Center Contact Plating:

Gold

Operating Temperature:

-

Insertion Loss:

-

## Environmental & Export classification

Moisture Sensitivity Level (MSL):

1 (Unlimited)

ECCN:

EAR99

REACH Status:

REACH Unaffected

HTSUS:

8536.69.4010



# SMA Plug, Solder Clamp for Semflex HP190 Cable

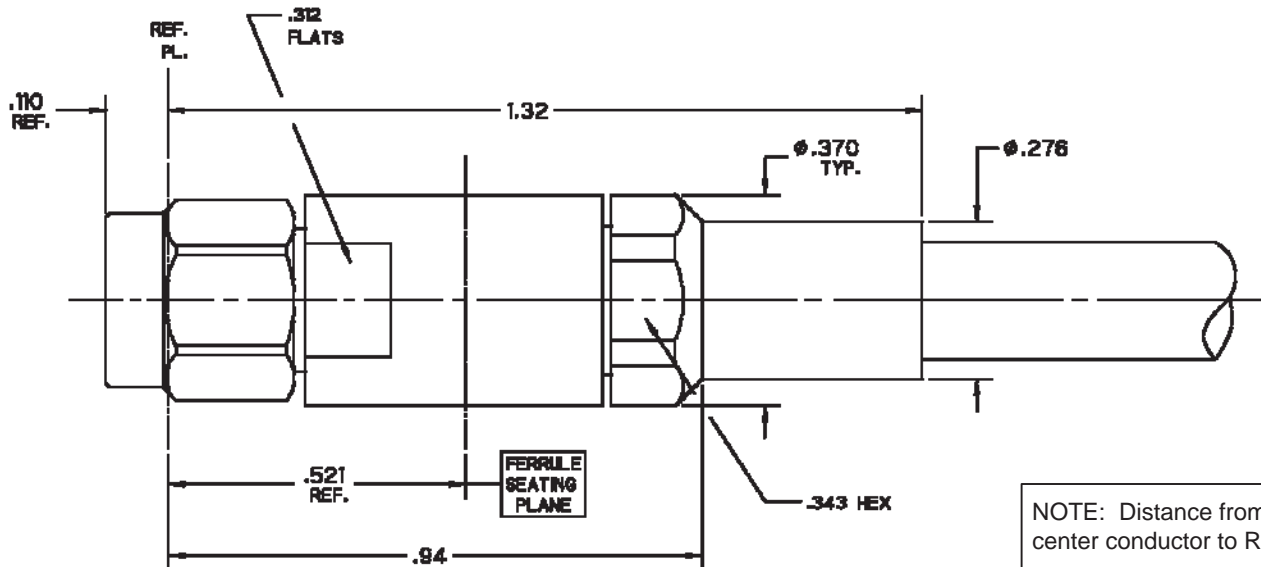

## NOTES:

### 1.0 Materials

- 1.1 Body, Coupling, and Clamp Nuts: Steel. Corrosion Resistant per ASTM-A582. UNS No. S30300.
- 1.2 Center Conductor: Beryllium Copper per ASTM-B196. UNS C17300.
- 1.3 Solder Ferrule: Brass per ASTM-B16. UNS C36000.
- 1.4 Lock Ring: Beryllium Copper per ASTM-B197. UNS C17200.
- 1.5 Gasket: Silicone Rubber per A-A-59588.
- 1.6 Insulators: PTFE Fluorocarbon per ASTM-D1710.

### 2.0 Finishes

- 2.1 Center Contact and Solder Ferrule: Gold Plate per ASTM-B488 50 Microinches Min. thickness over Electrolytic Nickel Plate per ASTM-B689 50 Microinches Min. thickness.
- 2.2 Body, Coupling, and Clamp Nuts: Passivated per SAE-AMS-2700.
- 2.3 Gasket, Lock Ring, and Dielectrics: None.

- 3.0 Interface: Type SMA plug per Crystek interface specification CC-SMAP (Meets MIL-STD-348. Fig. 310-1)



**CRYSTEK**  
**MICROWAVE**  
 A DIVISION OF CRYSTEK CORPORATION

# SMA Plug, Solder Clamp for Semflex HP190 Cable

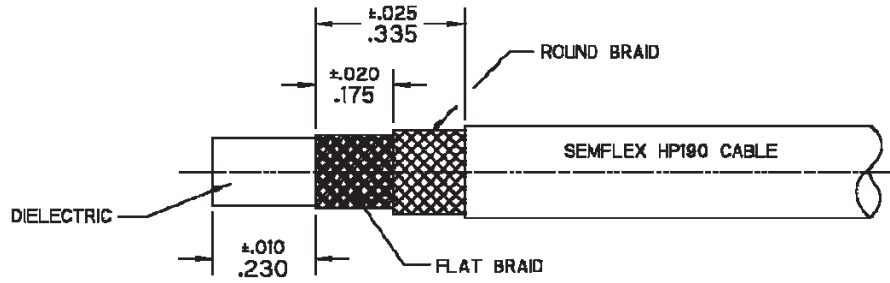

**Step 1** 1.1 Trim Cable as shown.

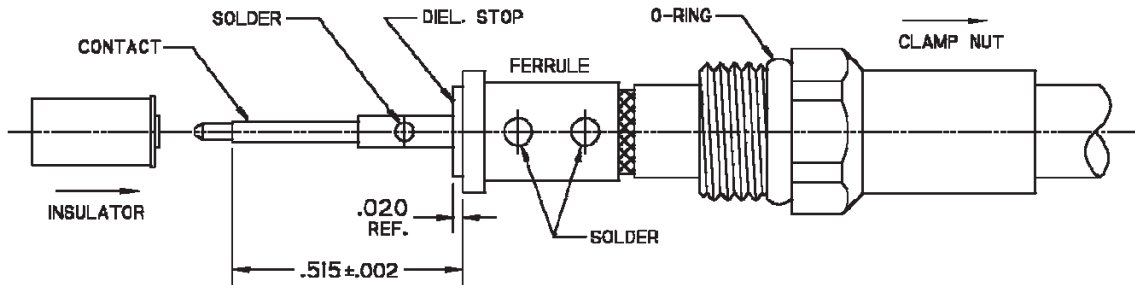

- 2.1 Slide clamp nut over cable in orientation shown.
- 2.2 Insert cable into solder ferrule until inner braid seats and solder to braids where shown.
- 2.3 Trim cable dielectric flush with face of ferrule.
- 2.4 Slide dielectric stop over cable center conductor and solder contact flush to stop to dimension shown.

**Step 2** 2.5 Slide insulator onto contact against shoulder.

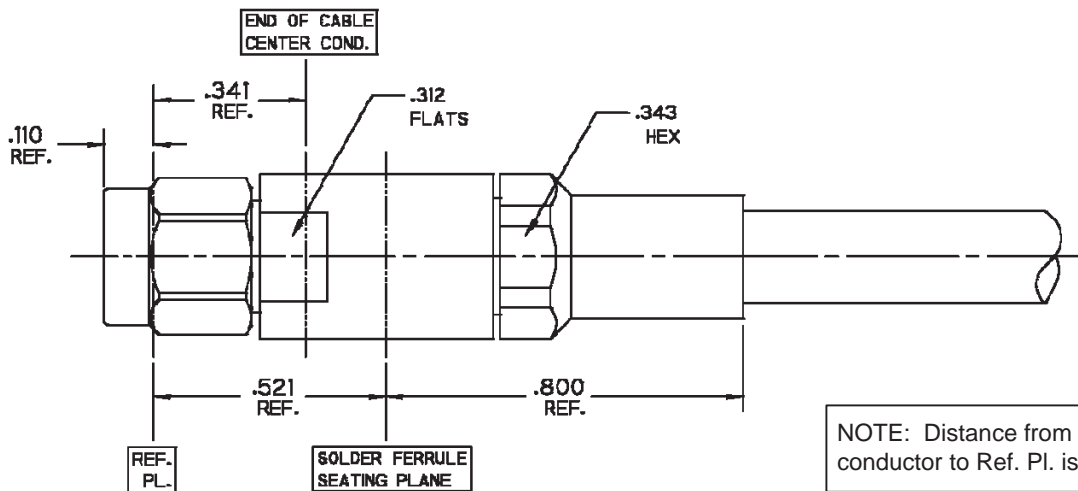

NOTE: Distance from end of cable center conductor to Ref. Pl. is 0.341 (Ref)

3.1 Insert cable/contact sub-assembly into connector until seated and tighten clamp nut to 25-35 in-lbs.

**Step 3**

<b>Product Control:</b>			
Crystek Part Number:	CS-SM-MSC	Release Date:	04-Jan-11
Revision Level:	A	Responsible:	K. Piotrowicz

## OUR CERTIFICATE

DiGi provide top-quality products and perfect service for customer worldwide through standardization, technological innovation and continuous improvement. DiGi through third-party certification, we stricly control the quality of products and services. Welcome your RFQ to

Email: [Info@DiGi-Electronics.com](mailto:Info@DiGi-Electronics.com)



Tel: +00 852-30501935

RFQ Email: [Info@DiGi-Electronics.com](mailto:Info@DiGi-Electronics.com)

DiGi is a global authorized distributor of electronic components.