

PSK-S12B-9 Datasheet

www.digi-electronics.com



<https://www.DiGi-Electronics.com>

DiGi Electronics Part Number	PSK-S12B-9-DG
Manufacturer	CUI Inc.
Manufacturer Product Number	PSK-S12B-9
Description	AC/DC CONVERTER 9V 12W
Detailed Description	Enclosed AC DC Converters 1 Output 9V 1.34A 90 ~ 264 VAC, 120 ~ 370 VDC Input

This model PSK-S12B-9 is available at DiGi Electronics.

DiGi Electronics offers a global database of semiconductor and electronic component datasheets.

We welcome your inquiries regarding pricing, lead time, or other product-related questions.

 [Request a Quote](#)

 [Datasheet Search](#)



Tel: +00 852-30501935

RFQ Email: Info@DiGi-Electronics.com

DiGi is a global authorized distributor of electronic components.

Purchase and inquiry

Manufacturer Product Number:

PSK-S12B-9

Series:

PSK-S12B (12W)

Type:

Enclosed

Voltage - Input:

90 ~ 264 VAC, 120 ~ 370 VDC

Voltage - Output 2:

-

Voltage - Output 4:

-

Power (Watts):

12 W

Features:

Universal Input

Efficiency:

85%

Package / Case:

4-DIP Module

Approval Agency:

CB Scheme, EN, FCC, IEC, UL

Load Regulation:

±1%

Manufacturer:

CUI Inc.

Product Status:

Active

Number of Outputs:

1

Voltage - Output 1:

9V

Voltage - Output 3:

-

Current - Output (Max):

1.34A

Applications:

Household Appliances, ITE (Commercial)

Operating Temperature:

-40°C ~ 75°C (With Derating)

Mounting Type:

Through Hole

Size / Dimension:

1.60" L x 1.10" W x 0.77" H (40.6mm x 27.9mm x 19.6mm)

Line Regulation:

±1%

Base Product Number:

PSK-S12

Environmental & Export classification

RoHS Status:

RoHS Compliant

REACH Status:

REACH Unaffected

HTSUS:

8504.40.9510

Moisture Sensitivity Level (MSL):

1 (Unlimited)

ECCN:

EAR99

SERIES: PSK-S12B | **DESCRIPTION:** AC-DC POWER SUPPLY

FEATURES

- universal input range (90 ~ 264 Vac)
- Class B emissions (EN55032/CISPR/FCC)
- certified to IEC/EN/UL 62368-1
- designed to meet IEC/EN 60335
- short circuit protection
- over voltage protection
- < 75 mW no-load power consumption
- Class II



MODEL	output voltage (Vdc)	output current		output power max (W)	ripple and noise ¹ max (mVp-p)	efficiency ² typ (%)
		min (A)	max (A)			
PSK-S12B-5	5	0	2.0	10	100	80
PSK-S12B-9	9	0	1.34	12	100	85
PSK-S12B-12	12	0	1.0	12	120	85
PSK-S12B-15	15	0	0.8	12	150	85
PSK-S12B-24	24	0	0.5	12	240	87

Notes: 1. At full load, nominal input, 20 MHz bandwidth oscilloscope, with 1 µF ceramic and 10 µF electrolytic capacitors on the output.
 2. At 230 Vac, full load, 25°C.
 3. All specifications are measured at Ta=25°C, nominal input voltage, and 75% rated output load unless otherwise specified.

PART NUMBER KEY

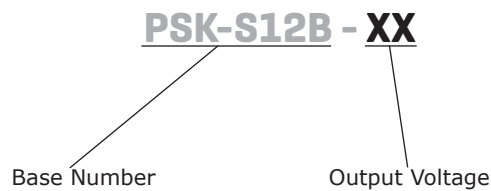

INPUT

parameter	conditions/description	min	typ	max	units
voltage		90		264	Vac
		120		370	Vdc
frequency		47		63	Hz
current	at 100 Vac, full load			400	mA
inrush current	at 240 Vac, cold start, 25°C			50	A
leakage current	at 264 Vac			0.25	mA

OUTPUT

parameter	conditions/description	min	typ	max	units
capacitive load	5 Vdc output models			2,000	μF
	9 Vdc output models			1,340	μF
	12 Vdc output models			1,000	μF
	15 Vdc output models			800	μF
	24 Vdc output models			500	μF
initial set point accuracy	at 100% load			±2	%
line regulation	measured at high line to low line at full load			±1	%
load regulation	measured at 10%~100% load			±1	%
start-up time				3	s
hold-up time	at 115 Vac		10		ms
switching frequency			65		kHz
temperature coefficient			±0.05		%/°C

PROTECTIONS

parameter	conditions/description	min	typ	max	units
over voltage protection	hiccup, auto recovery				
	5 Vdc output models			6.3	Vdc
	9 Vdc output models			12.6	Vdc
	12 Vdc output models			15.8	Vdc
	15 Vdc output models			18.9	Vdc
	24 Vdc output models			31.5	Vdc
short circuit protection	hiccup, auto recovery				

SAFETY & COMPLIANCE

parameter	conditions/description	min	typ	max	units
isolation voltage	input to output for 1 minute	3,000			Vac
isolation resistance		100			MΩ
safety approvals	certified to IEC/EN/UL 62368-1 designed to meet IEC/EN 60335				
safety class	Class II				
conducted emissions	EN55032 2015, EN61000-6-3 2007+A1: 2011+AC: 2012, Class B, 47 CFR FCC Part 15 Subpart B (Class B)				
radiated emissions	EN55032 2015, EN61000-6-3 2007+A1: 2011+AC: 2012, Class B, 47 CFR FCC Part 15 Subpart B (Class B)				
harmonic current emissions	EN61000-3-2:2014				
voltage fluctuations & flicker	EN61000-3-3:2013				
ESD	IEC61000-4-2:2008				
radiated immunity	IEC61000-4-3:2010				
EFT/burst	IEC61000-4-4:2012				
surge	IEC61000-4-5:2014				

SAFETY & COMPLIANCE (CONTINUED)

parameter	conditions/description	min	typ	max	units
conducted immunity	IEC61000-4-6:2013				
power frequency magnetic field	IEC61000-4-8:2009				
voltage dips & interruptions	IEC61000-4-11:2004				
MTBF	as per MIL-HDBK-217F, at 115 Vac, 25°C, GB				
	5 Vdc output model		580,000		hours
	9 Vdc output model		870,000		hours
	12 Vdc output model		660,000		hours
	15 Vdc output model		740,000		hours
	24 Vdc output model		620,000		hours
RoHS	yes				

Notes: 4. The power supply is considered a component which will be installed into final equipment. The final equipment still must be tested to meet the necessary EMC directives.

ENVIRONMENTAL

parameter	conditions/description	min	typ	max	units
operating temperature	see derating curves	-40		75	°C
storage temperature		-40		85	°C
operating humidity	non-condensing			93	%
altitude				5,000	m
vibration	as per MIL-STD-810F Table 514.5C-VIII; 15~2000 Hz for 1 hour on each axis for 3 hours		4		G
shock	as per MIL-STD-810F Table 516.5, Table 516.5-1; for 10 ms on each axis 3 times		75		G

DERATING CURVE

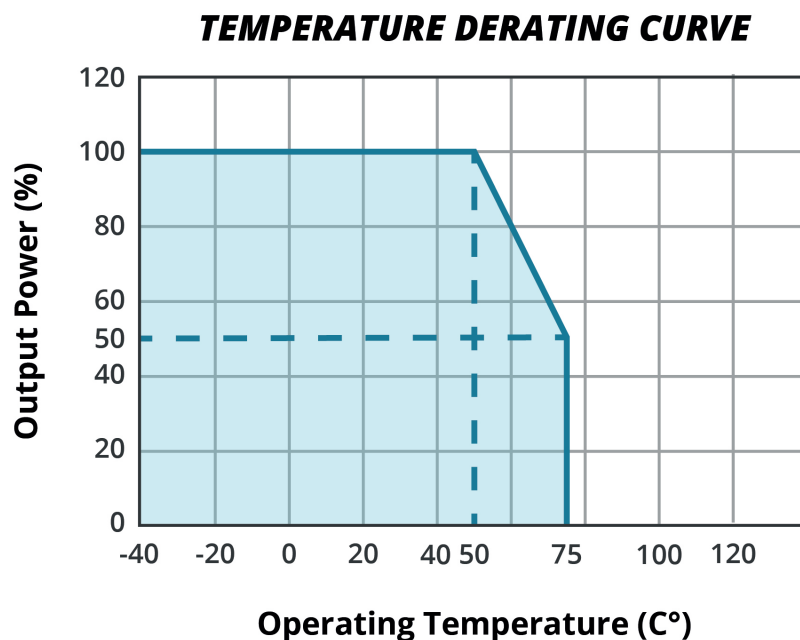

MECHANICAL

parameter	conditions/description	min	typ	max	units
dimensions	1.600 x 1.100 x 0.772 (40.64 x 27.94 x 19.60 mm)				inches
weight			40		g

MECHANICAL DRAWING

units: inch [mm]
tolerance: ±0.020[±0.50]

PIN CONNECTIONS	
PIN	Function
1	AC (N)
2	AC (L)
3	-Vo
4	+Vo

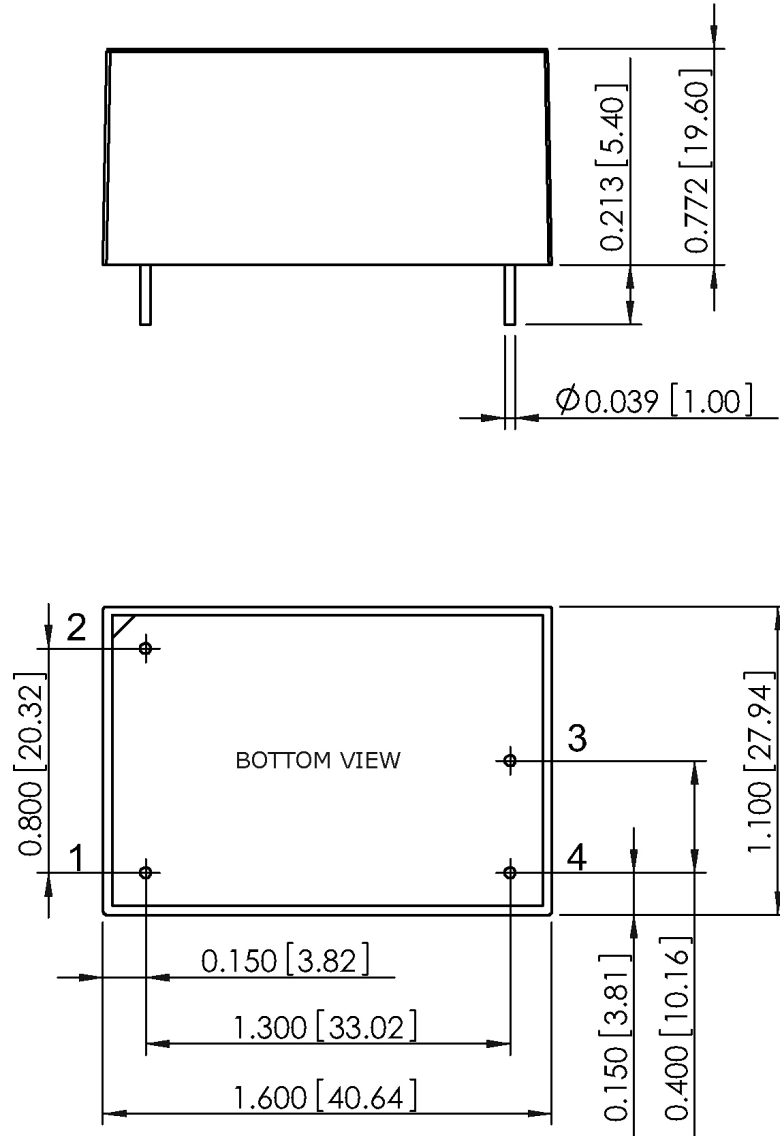

INSTALLATION INSTRUCTIONS

The mounting holes should all be 1.5 mm in diameter. A minimum of 4 mm clearance is required for all four sides of the unit and a minimum of 5 mm clearance is required above the top surface of the unit.

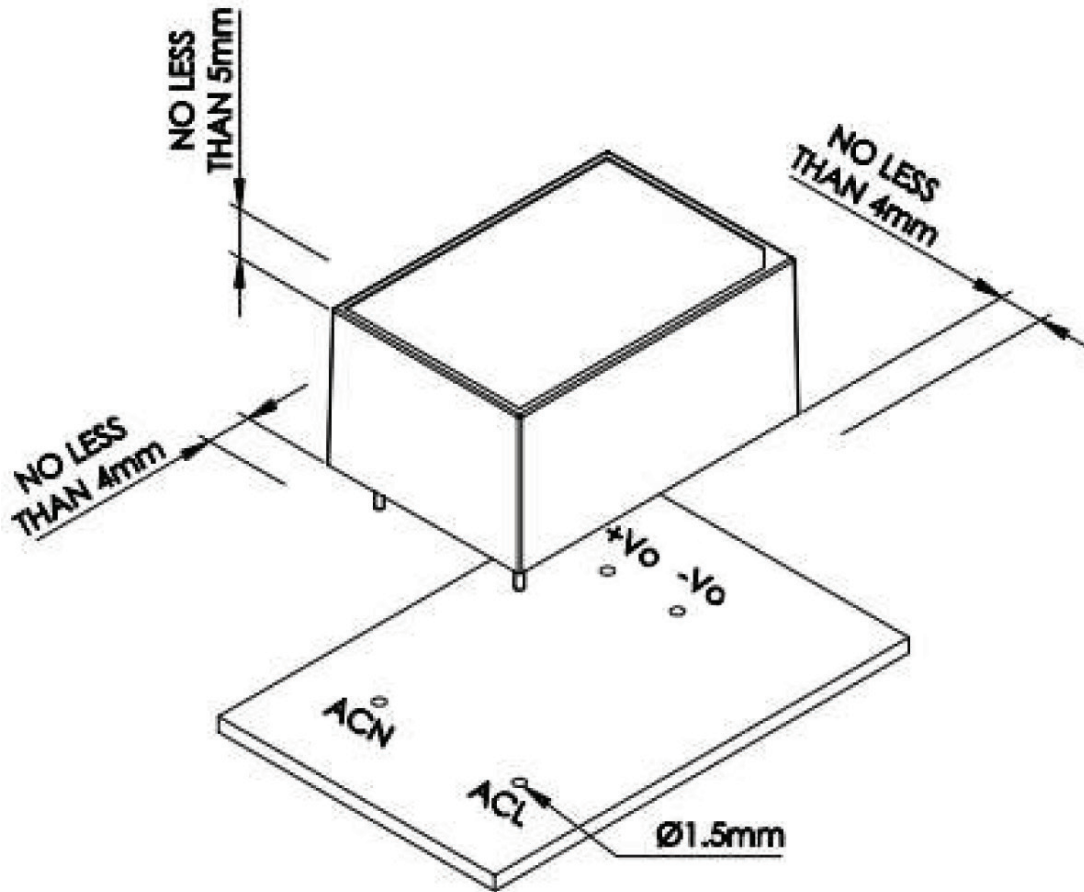

REVISION HISTORY

rev.	description	date
1.0	initial release	02/13/2020
1.01	derating curve drawing updated	02/25/2021

The revision history provided is for informational purposes only and is believed to be accurate.



Headquarters
20050 SW 112th Ave.
Tualatin, OR 97062
800.275.4899

Fax 503.612.2383
cui.com
techsupport@cui.com

CUI offers a two (2) year limited warranty. Complete warranty information is listed on our website.

CUI reserves the right to make changes to the product at any time without notice. Information provided by CUI is believed to be accurate and reliable. However, no responsibility is assumed by CUI for its use, nor for any infringements of patents or other rights of third parties which may result from its use.

CUI products are not authorized or warranted for use as critical components in equipment that requires an extremely high level of reliability. A critical component is any component of a life support device or system whose failure to perform can be reasonably expected to cause the failure of the life support device or system, or to affect its safety or effectiveness.

OUR CERTIFICATE

DiGi provide top-quality products and perfect service for customer worldwide through standardization, technological innovation and continuous improvement. DiGi through third-party certification, we strictly control the quality of products and services. Welcome your RFQ to

Email: Info@DiGi-Electronics.com



Tel: +00 852-30501935

RFQ Email: Info@DiGi-Electronics.com

DiGi is a global authorized distributor of electronic components.