

EL817(M)(B))-VG Datasheet

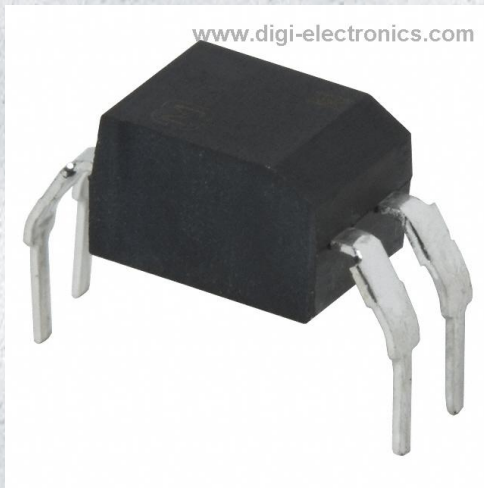

<https://www.DiGi-Electronics.com>

DiGi Electronics Part Number	EL817(M)(B))-VG-DG
Manufacturer	Everlight Electronics Co Ltd
Manufacturer Product Number	EL817(M)(B))-VG
Description	OPTOISOLTR 5KV TRANSISTOR 4-DIP
Detailed Description	Optoisolator Transistor Output 5000Vrms 1 Channel 4-DIP

This model EL817(M)(B))-VG is available at DiGi Electronics.

DiGi Electronics offers a global database of semiconductor and electronic component datasheets.

We welcome your inquiries regarding pricing, lead time, or other product-related questions.

 [Request a Quote](#)

 [Datasheet Search](#)



Tel: +00 852-30501935

RFQ Email: Info@DiGi-Electronics.com

DiGi is a global authorized distributor of electronic components.

Purchase and inquiry

Manufacturer Product Number:

EL817(M)(B))-VG

Series:

-

Number of Channels:

1

Current Transfer Ratio (Min):

130% @ 5mA

Turn On / Turn Off Time (Typ):

-

Input Type:

DC

Voltage - Output (Max):

80V

Voltage - Forward (Vf) (Typ):

1.2V

Vce Saturation (Max):

200mV

Mounting Type:

Through Hole

Supplier Device Package:

4-DIP

Manufacturer:

Everlight Electronics Co Ltd

Product Status:

Active

Voltage - Isolation:

5000Vrms

Current Transfer Ratio (Max):

260% @ 5mA

Rise / Fall Time (Typ):

6µs, 8µs

Output Type:

Transistor

Current - Output / Channel:

50mA

Current - DC Forward (If) (Max):

60 mA

Operating Temperature:

-55°C ~ 110°C

Package / Case:

4-DIP (0.400", 10.16mm)

Base Product Number:

EL817

Environmental & Export classification

RoHS Status:

ROHS3 Compliant

ECCN:

EAR99

Moisture Sensitivity Level (MSL):

1 (Unlimited)

HTSUS:

8541.49.8000

EVERLIGHT

DATASHEET

4 PIN DIP PHOTOTRANSISTOR PHOTOCOUPLER EL817-G Series

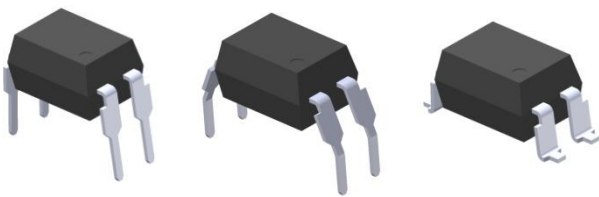

Schematic

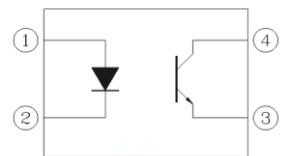

Pin Configuration

1. Anode
2. Cathode
3. Emitter
4. Collector

Features:

- Compliance Halogens Free
(Br < 900 ppm, Cl < 900 ppm, Br+Cl < 1500 ppm)
- Current transfer ratio
(CTR: 50~600% at $I_F = 5\text{mA}$, $V_{CE} = 5\text{V}$)
- High isolation voltage between input and output (Viso = 5000Vrms)
- Creepage distance > 7.62mm
- Operating temperature up to +110°C
- Compact small outline package
- Compliance with EU REACH.
- The product itself will remain within RoHS compliant version
- UL and cUL approved(No.E214129)
- VDE approved (No.132249)
- SEMKO approved
- NEMKO approved
- DEMKO approved
- FIMKO approved
- CQC approved

Description

The EL817-G series of devices each consist of an infrared emitting diodes, optically coupled to a phototransistor detector. They are packaged in a 4-pin DIP package and available in wide-lead spacing and SMD option.

Applications

- Programmable controllers
- System appliances, measuring instruments
- Telecommunication equipments
- Home appliances, such as fan heaters, etc.
- Signal transmission between circuits of different potentials and impedances

Absolute Maximum Ratings (Ta=25°C)

	Parameter	Symbol	Rating	Unit
Input	Forward current	I_F	60	mA
	Peak forward current (1us, pulse)	I_{FP}	1	A
	Reverse voltage	V_R	6	V
	Power dissipation	P_D	100	mW
	Derating factor (above $T_a = 100^\circ\text{C}$)		2.9	mW/°C
Output	Power dissipation	P_C	150	mW
	Derating factor (above $T_a = 100^\circ\text{C}$)		5.8	mW/°C
	Collector current	I_C	50	mA
	Collector-Emitter voltage	V_{CEO}	80	V
	Emitter-Collector voltage	V_{ECO}	7	V
Total Power Dissipation		P_{TOT}	200	mW
Isolation Voltage* ¹		V_{ISO}	5000	V rms
Operating Temperature		T_{OPR}	-55 to 110	°C
Storage Temperature		T_{STG}	-55 to 125	°C
Soldering Temperature* ²		T_{SOL}	260	°C

Notes:

*1 AC for 1 minute, R.H.= 40 ~ 60% R.H. In this test, pins 1, 2 are shorted together, and pins 3, 4 are shorted together.

*2 For 10 seconds

Electro-Optical Characteristics (Ta=25°C unless specified otherwise)
Input

Parameter	Symbol	Min.	Typ.	Max.	Unit	Condition
Forward Voltage	V_F	-	1.2	1.4	V	$I_F = 20\text{mA}$
Reverse Current	I_R	-	-	10	μA	$V_R = 4\text{V}$
Input capacitance	C_{in}	-	30	250	pF	$V = 0, f = 1\text{kHz}$

Output

Parameter	Symbol	Min	Typ.	Max.	Unit	Condition
Collector-Emitter dark current	I_{CEO}	-	-	100	nA	$V_{CE} = 20\text{V}, I_F = 0\text{mA}$
Collector-Emitter breakdown voltage	BV_{CEO}	80	-	-	V	$I_C = 0.1\text{mA}$
Emitter-Collector breakdown voltage	BV_{ECO}	7	-	-	V	$I_E = 0.1\text{mA}$

Transfer Characteristics

Parameter	Symbol	Min	Typ.	Max.	Unit	Condition
Current Transfer ratio	EL817	50	-	600	%	$I_F = 5\text{mA}, V_{CE} = 5\text{V}$
	EL817A	80	-	160		
	EL817B	130	-	260		
	EL817C	200	-	400		
	EL817D	300	-	600		
	EL817X	100	-	200		
	EL817Y	150	-	300		
Collector-Emitter saturation voltage	$V_{CE(sat)}$	-	0.1	0.2	V	$I_F = 20\text{mA}, I_C = 1\text{mA}$
Isolation resistance	R_{IO}	5×10^{10}	-	-	Ω	$V_{IO} = 500\text{Vdc}, 40\sim 60\% \text{ R.H.}$
Floating capacitance	C_{IO}	-	0.6	1.0	pF	$V_{IO} = 0, f = 1\text{MHz}$
Cut-off frequency	f_c	-	80	-	kHz	$V_{CE} = 5\text{V}, I_C = 2\text{mA}$ $R_L = 100\Omega, -3\text{dB}$
Rise time	t_r	-	6	18	μs	$V_{CE} = 2\text{V}, I_C = 2\text{mA}, R_L = 100\Omega$
Fall time	t_f	-	8	18	μs	

* Typical values at $T_a = 25^\circ\text{C}$

Typical Electro-Optical Characteristics Curves

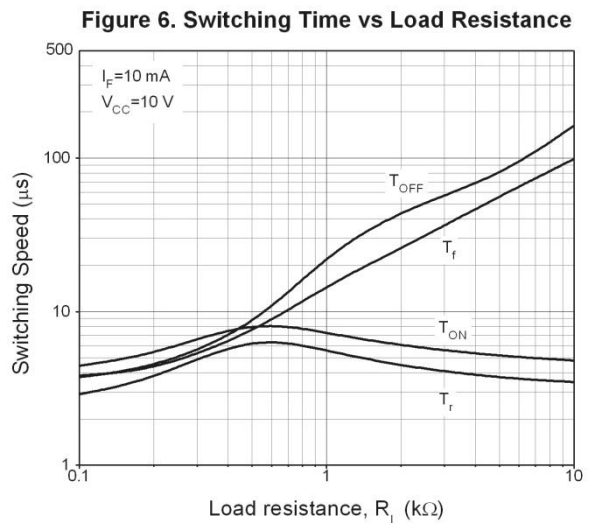
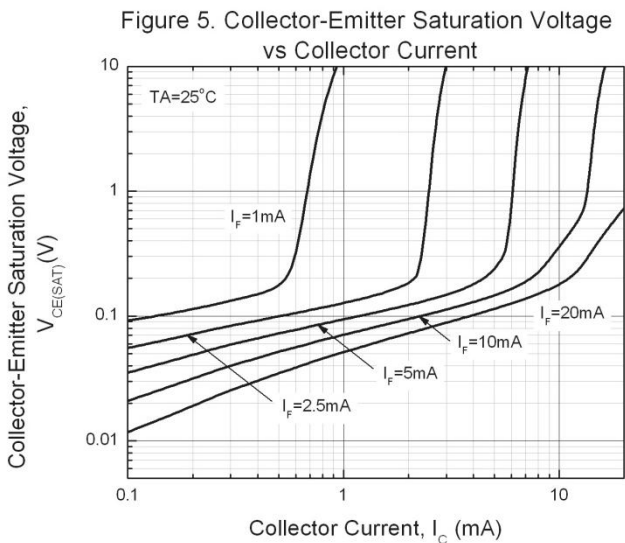
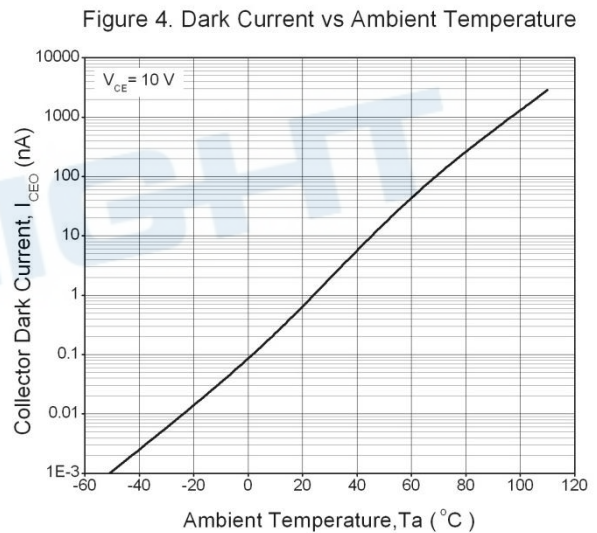
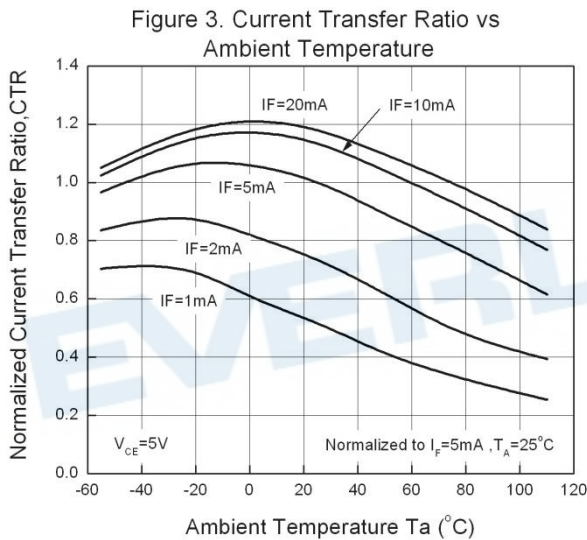
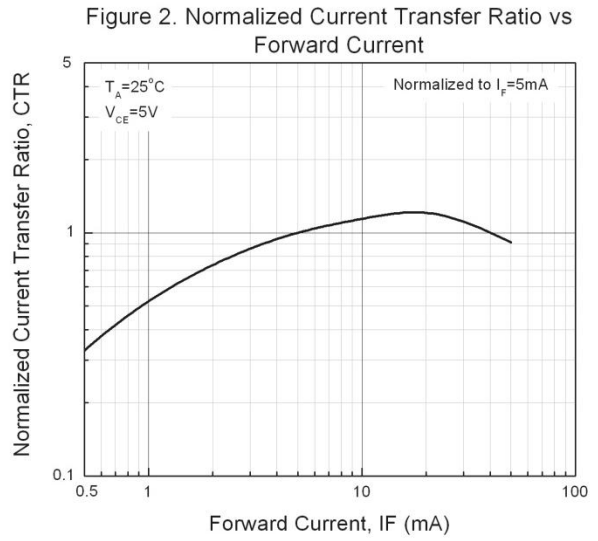
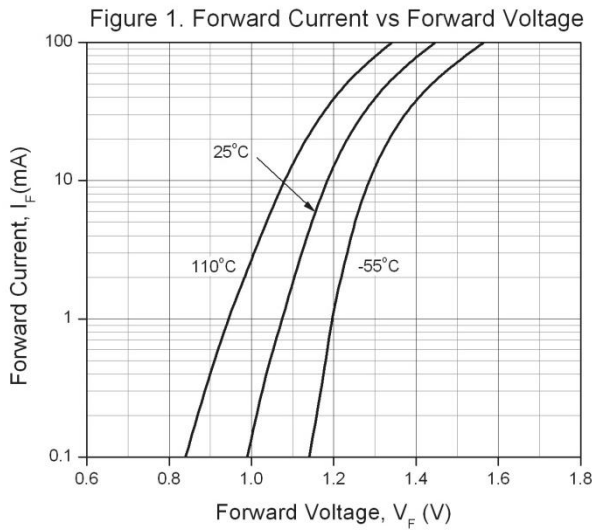

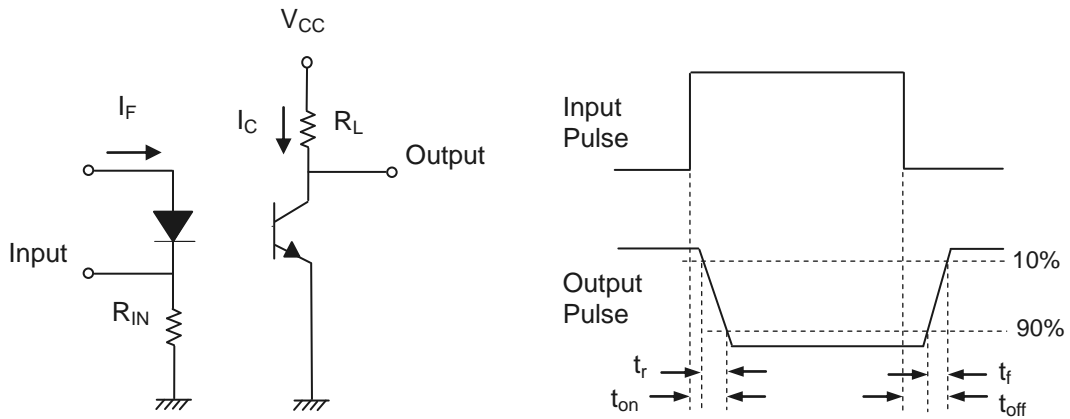

Figure 7. Switching Time Test Circuit & Waveforms

EVERLIGHT

Order Information

Part Number

EL817X(Y)(Z)-FVG

Note

- X = Lead form option (S1, S2, M or none)
- Y = CTR Rank (A, B, C, D, X, Y or none)
- Z = Tape and reel option (TU, TD or none)
- F = Lead frame option (F: Iron, None: copper)
- V = VDE safety (optional)
- G = Halogens free

Option	Description	Packing quantity
None	Standard DIP-4	100 units per tube
M	Wide lead bend (0.4 inch spacing)	100 units per tube
S1 (TU)	Surface mount lead form (low profile) + TU tape & reel option	1500 units per reel
S1 (TD)	Surface mount lead form (low profile) + TD tape & reel option	1500 units per reel
S2 (TU)	Surface mount lead form (low profile) + TU tape & reel option	2000 units per reel
S2 (TD)	Surface mount lead form (low profile) + TD tape & reel option	2000 units per reel

Package Dimension (Dimensions in mm)

Standard DIP Type

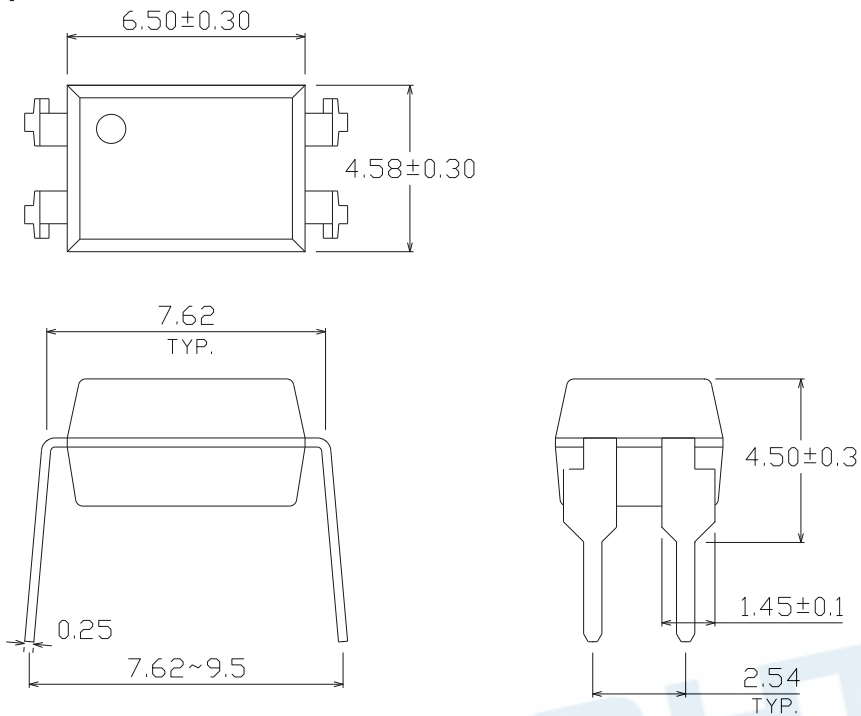

Option M Type

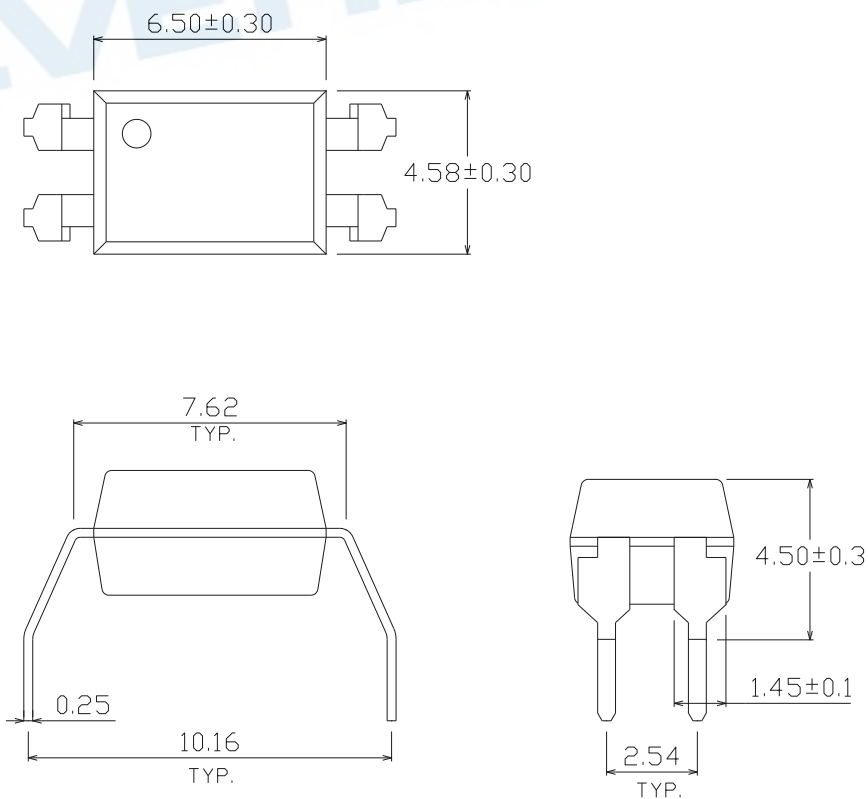

Option S1 Type

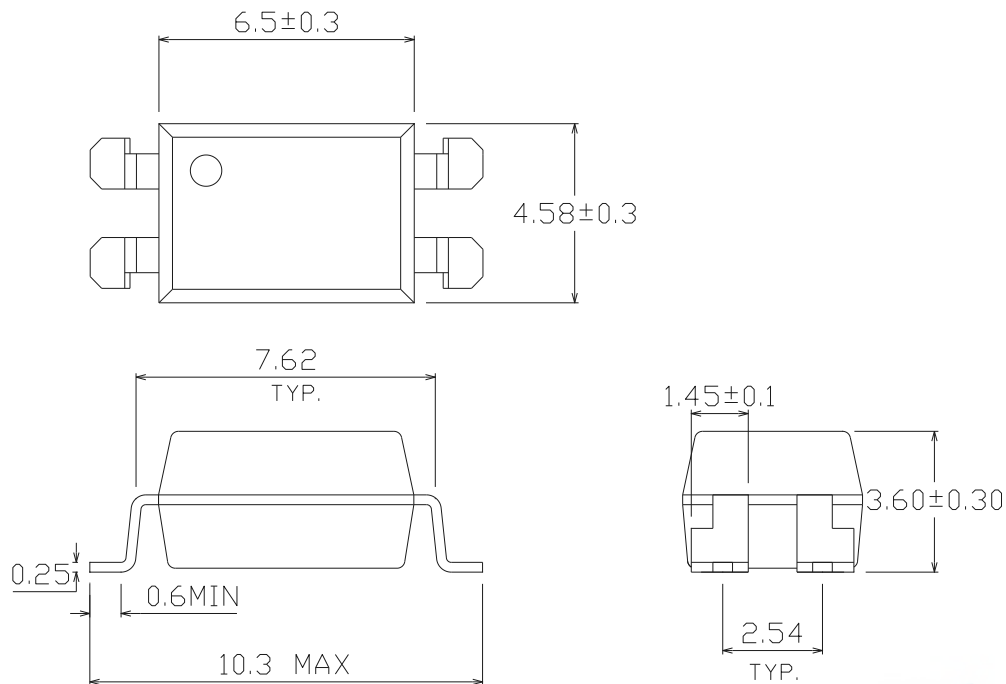

Option S2 Type

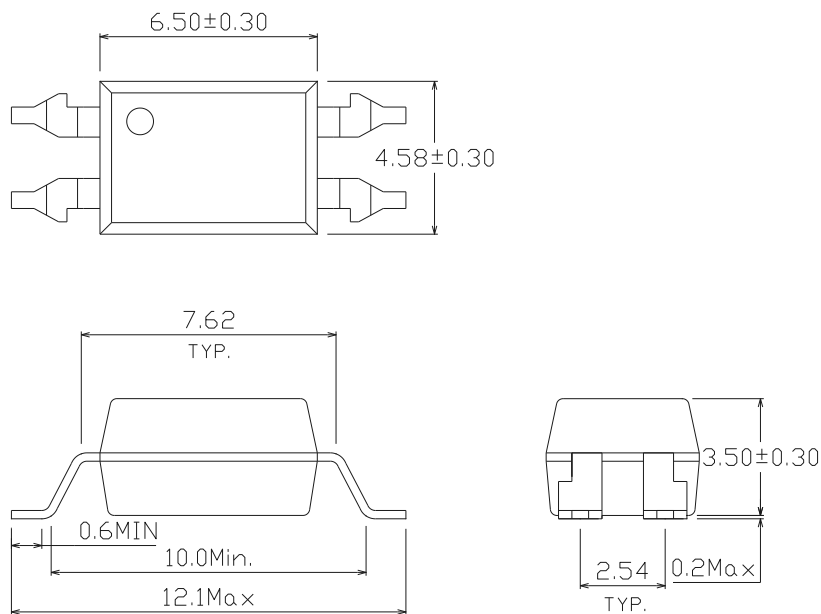

Recommended pad layout for surface mount leadform

For S1 option

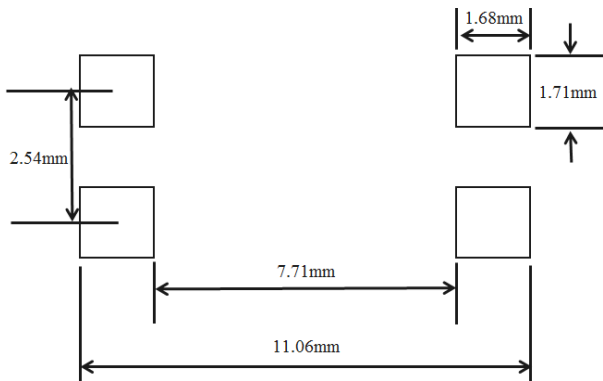

For S2 option

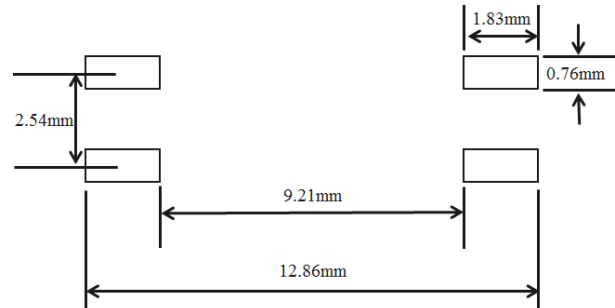

Notes

Suggested pad dimension is just for reference only.
Please modify the pad dimension based on individual need.

Device Marking



Notes

EL denotes EVERLIGHT
817 denotes Device Number
F denotes Factory Code (G: China and Green part)
R denotes CTR Rank (A, B, C, D, X, Y or none)
Y denotes 1 digit Year code
WW denotes 2 digit Week code
V denotes VDE (optional)

Tape & Reel Packing Specifications

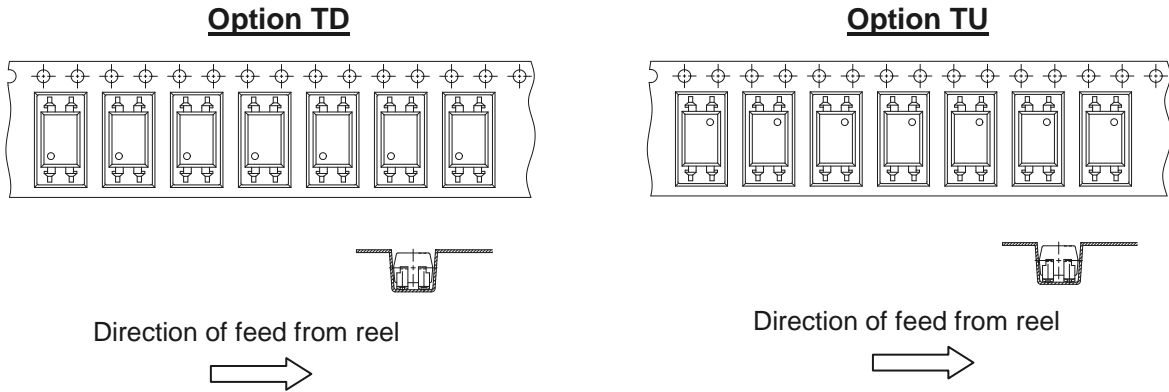

Tape dimensions

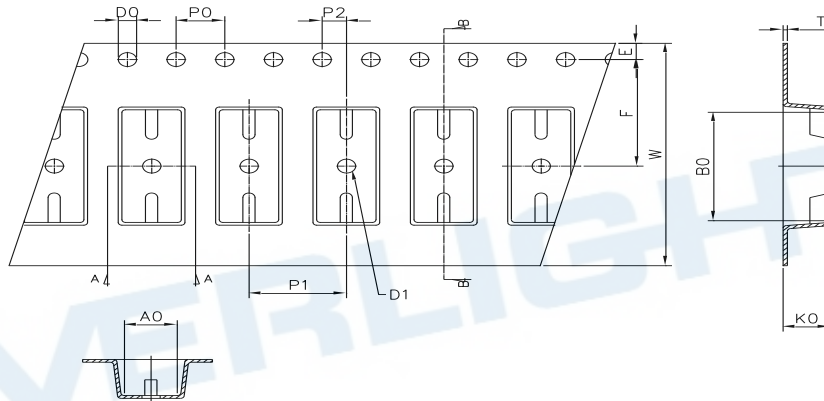

Dimension No.	Ao	Bo	Do	D1	E	F
Dimension (mm) S1	4.90±0.1	10.40±0.1	1.5±0.1	1.50±0.1	1.75±0.1	7.50±0.1
Dimension (mm) S2	4.88±0.1	12.55±0.1	1.5±0.1	1.50±0.1	1.75±0.1	11.5±0.1
Dimension No.	Po	P1	P2	t	W	Ko
Dimension (mm) S1	4.00±0.1	8.00±0.1	2.00±0.1	0.40±0.1	16.00±0.3	4.60±0.1
Dimension (mm) S2	4.00±0.1	8.00±0.1	2.00±0.1	0.40±0.1	24.00±0.3	4.00±0.1

Precautions for Use

1. Soldering Condition

1.1 (A) Maximum Body Case Temperature Profile for evaluation of Reflow Profile

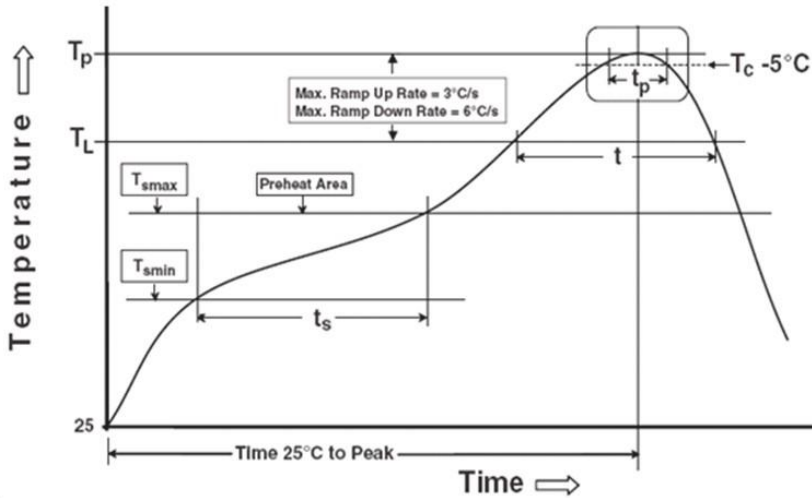

Note:

Reference: IPC/JEDEC J-STD-020D

Preheat

Temperature min (T_{smin})	150 °C
Temperature max (T_{smax})	200°C
Time (T_{smin} to T_{smax}) (t_s)	60-120 seconds
Average ramp-up rate (T_{smax} to T_p)	3 °C/second max

Other

Liquidus Temperature (T_L)	217 °C
Time above Liquidus Temperature (t_L)	60-100 sec
Peak Temperature (T_p)	260°C
Time within 5 °C of Actual Peak Temperature: $T_p - 5^\circ\text{C}$	30 s
Ramp- Down Rate from Peak Temperature	6°C /second max.
Time 25°C to peak temperature	8 minutes max.
Reflow times	3 times

DISCLAIMER

1. Above specification may be changed without notice. EVERLIGHT will reserve authority on material change for above specification.
2. The graphs shown in this datasheet are representing typical data only and do not show guaranteed values.
3. When using this product, please observe the absolute maximum ratings and the instructions for use outlined in these specification sheets. EVERLIGHT assumes no responsibility for any damage resulting from use of the product which does not comply with the absolute maximum ratings and the instructions included in these specification sheets.
4. These specification sheets include materials protected under copyright of EVERLIGHT. Reproduction in any form is prohibited without the specific consent of EVERLIGHT.
5. This product is not intended to be used for military, aircraft, automotive, medical, life sustaining or life saving applications or any other application which can result in human injury or death. Please contact authorized Everlight sales agent for special application request.
6. Statements regarding the suitability of products for certain types of applications are based on Everlight's knowledge of typical requirements that are often placed on Everlight products in generic applications. Such statements are not binding statements about the suitability of products for a particular application. It is the customer's responsibility to validate that a particular product with the properties described in the product specification is suitable for use in a particular application. Parameters provided in datasheets and/or specifications may vary in different applications and performance may vary over time. All operating parameters, including typical parameters, must be validated for each customer application by the customer's technical experts. Product specifications do not expand or otherwise modify Everlight's terms and conditions of purchase, including but not limited to the warranty expressed therein.

OUR CERTIFICATE

DiGi provide top-quality products and perfect service for customer worldwide through standardization, technological innovation and continuous improvement. DiGi through third-party certification, we stricly control the quality of products and services. Welcome your RFQ to

Email: Info@DiGi-Electronics.com



Tel: +00 852-30501935

RFQ Email: Info@DiGi-Electronics.com

DiGi is a global authorized distributor of electronic components.